

P/N	XX(FT)	L(MM)	TOLERANCE(MM)
BDIS-BNC55-06	06	1829	+75/-0
BDIS-BNC55-10	10	3048	+75/-0
BDIS-BNC55-25	25	7620	+150/-0

NOTE:

1. CABLE: (28AWG X 5 COAX, EACH COAX SPIRAL SHIELDED, UL1354, COLOR CODE: RED, GREEN, BLUE, GREY, BLACK), AL-FOIL AND BRAID(85%) SHIELDED(A-M ALLOY) WITH DRAIN WIRE(BARE COPPER), UL2919 + CUL IA FT1, BLACK PVC JACKET. $\phi 9.0 \pm 0.15$ mm
2. CONNECTOR: P1~P10: BNC MALE, GOLD FLASH CONTACTS, 75 OHM,
3. ALL HOOD & STRAIN RELIEF : MOLDED BLACK PVC.
4. PACKING: EACH CABLE IN A POLY-BAG.
5. 100% ELECTRICAL TEST

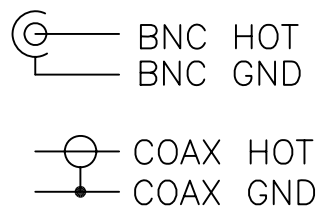

PIN OUT

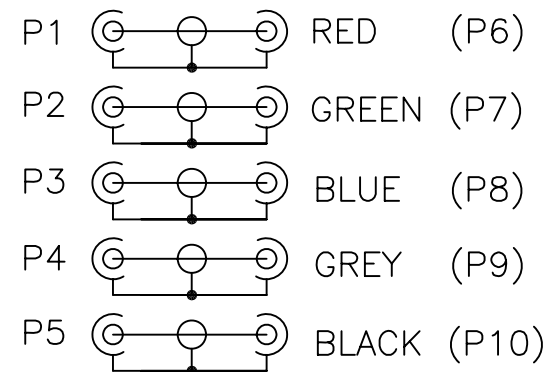

NET MECHANISM Corp				
www.cabling-ol.net				
SCALE	NONE		REV	B
UNIT	MM			
SHEET	1/1	DWG NO.		
DATE	12/21/10			
TITLE				
5BNCM TO 5BNCM				
PART NO.				
BDIS-BNC55-XX				