

NOTE:

1. CABLE: (28AWG X 5 COAX, EACH COAX SPIRAL SHIELDED, UL1354, COLOR CODE: RED, GREEN, BLUE, GREY, BLACK), AL-FOIL AND BRAID(85%) SHIELDED WITH DRAIN, UL2919 + CUL IA FT1, BLACK PVC JACKET.
2. CONNECTOR: P1: HIGH DENSITY 15PIN MALE, SOLDER TYPE, GOLD FLASH CONTACTS, BLACK PBT INSULATON, THE 9TH PIN UNLOADED. P2, P3, P4, P5, P6: BNC MALE: GOLD FLASH CONTACTS, 75 OHM .
3. THUMB SCREW TO BE MOLDED.
4. FERRITE CORE(C5A RH: $\phi 17.5 \times \phi 10.2 \times 28.5\text{mm}$) TO BE MOLDED.
5. P1 SHIELDING: COPPER-FOIL TAPE COVERED PREMOLD AND 360° SOLDER TO CONNECTOR SHELL AND CABLE BRAID.
6. ALL HOOD & STRAIN RELIEF & FERRITE CORE: MOLDED BLACK PVC.
7. TESTING:100% ELECTRICAL TEST.

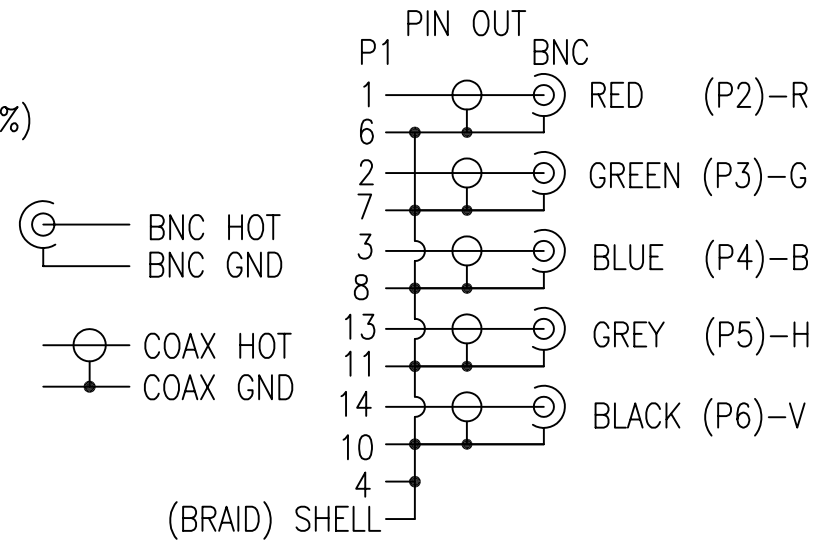

CHART:

P/N	XX(FT)	L(MM)	TOLERANCE(MM)
BDIS-D15BNC5-03	3	914	+50/-0
BDIS-D15BNC5-06	6	1829	+75/-0
BDIS-D15BNC5-10	10	3048	+75/-0
BDIS-D15BNC5-15	15	4572	+75/-0

NET MECHANISM Corp www.cabling-ol.net				
SCALE	NONE		REV	B
UNIT	MM			
SHEET	1/1	DWG NO.		
DATE	03/08/05			
TITLE	HDB15/M TO 5BNC/M			
PART NO.	BDIS-D15BNC5-XX			