

ELECTRONIC TEST:  
 1.ALL CABLE 100% TEST,OPEN ,SHORT,MISS WIRE  
 2.RESISTANCE:3 ohm max  
 3.I.RESISTANCE:10M ohm min  
 4.HI-POT:300V DC/10ms

- NOTES:
- CABLE: SERIAL ATA CABLE:{26AWG(1/0.404)\*2C+AL.MY+DRAIN WIRE[28AWG(1/0.32)\*2C]}\*2F,OD:2.3\*8.30mm RED PVC JACKET.
  - CABLE: UL 1007 20AWG COLOR:BLACK;RED.
  - P1: SERIAL ATA 13PIN FEMALE.BLACK PBT INSULATION.CRIMPING TYPE,GOLD PLATED CONTACTS.
  - P2: HOUSING: HSG-BIG4PM-01, WHITE; TER: TE-BIG4PM-01, TINNED.
  - P3: SERIAL ATA 7PIN PLUG,CRIMPING TYPE,WITH LATCH. GOLD PLATED CONTACTS.
  - ALL HOOD MOLDING PVC 45P BLACK.
  - MOLD NO:SATA76-01.SATA-06.

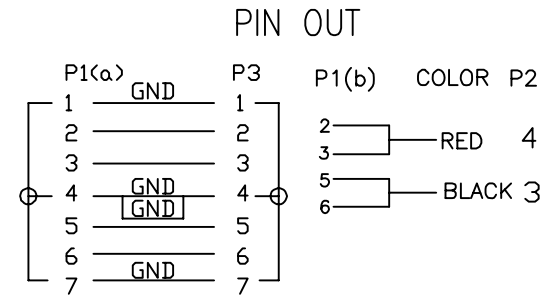
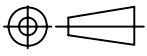

NET MECHANISM Corp www.cabling-ol.net				
SCALE	NONE		REV	B
UNIT	MM			
SHEET	1/1	DWG NO.		
DATE	02/03/12			
TITLE SATA 7P/M TO SAS 13P/F+BIG 4P HSG				
PART NO. SAS13-SATA-PW-XX				