

100M/reel

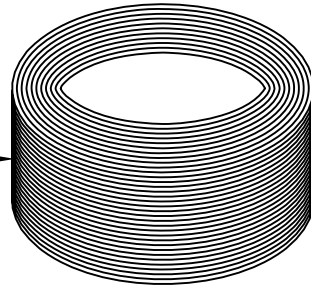

CABLE:UL 2725 #28*2P+#28*2C+AEB,OD:3.0
BLACK PVC JACKET.
(B-U22828-3.0-BK-01)



Four reels are putted in one box.

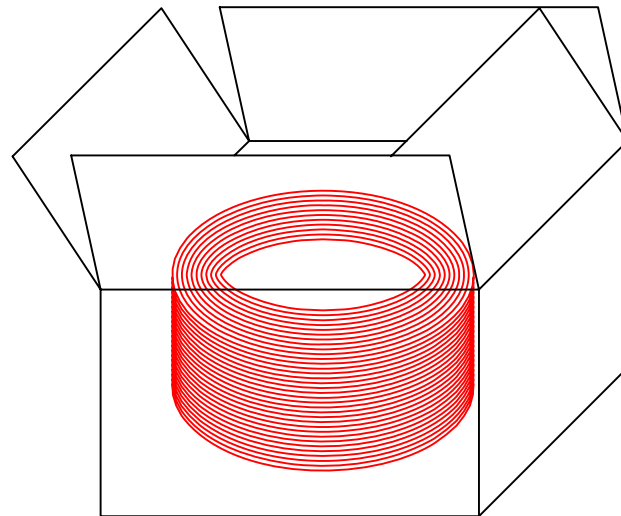

Note:

The cable should be assembled USB
AM plug with no molding, and not in
another end.

NOTE:

- 1)One reel is 100M, putting Four reels in one box.
- 2)One reel is connective.
(box dimension:380*380*280MM).
- 3)The two reels are put into a big waterproof bag,
and then put them into the box(T-BLK-35-47-8C).

NET MECHANISM Corp
www.cabling-ol.net

SCALE	NONE		REV	A
UNIT	MM			
SHEET	1/1	DWG NO.		
DATE	10/15/10			
TITLE		UL 2725 CABLE		
PART NO.		BC-USB2GH-100		

200M/reel

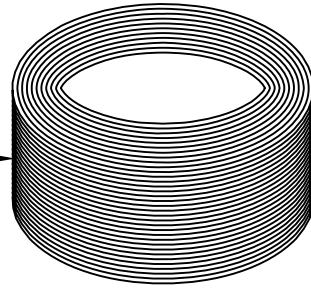

Two reels are putted in one box.

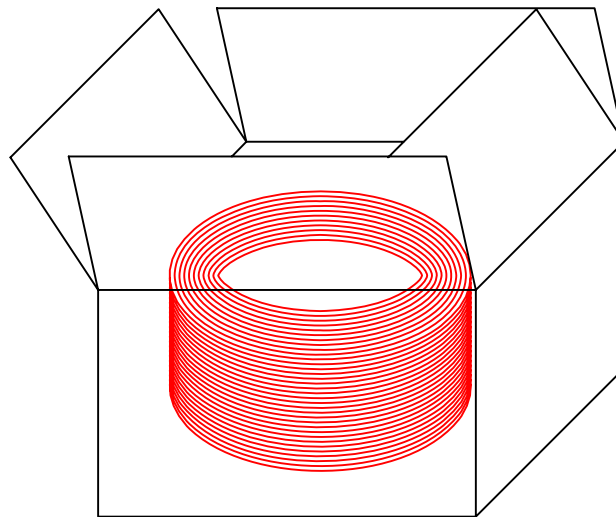

CABLE:UL 2725 #28*2P+#28*2C+AEB,OD:3.0
BLACK PVC JACKET.
(B-U22828-3.0-BK-01)

Note:
The cable should be assembled USB
AM plug with no molding, and not in
another end.

NOTE:

- 1)One reel is 200M, putting two reels in one box.
- 2)One reel is connective.
(box dimension:380*380*280MM).
- 3)The two reels are put into a big waterproof bag,
and then put them into the box(T-BLK-35-47-8C).

NET MECHANISM Corp
www.cabling-ol.net

SCALE	NONE		REV	A
UNIT	MM			
SHEET	1/1	DWG NO.		
DATE	10/15/10			
TITLE		UL 2725 CABLE		
PART NO.		BC-USB2GH-200		

300M/reel

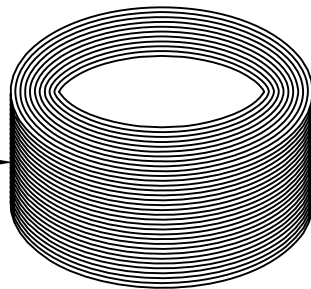

CABLE:UL 2725 #28*2P+#28*2C+AEB,OD:3.0
BLACK PVC JACKET.
(B-U22828-3.0-BK-01)



Two reels are putted in one box.

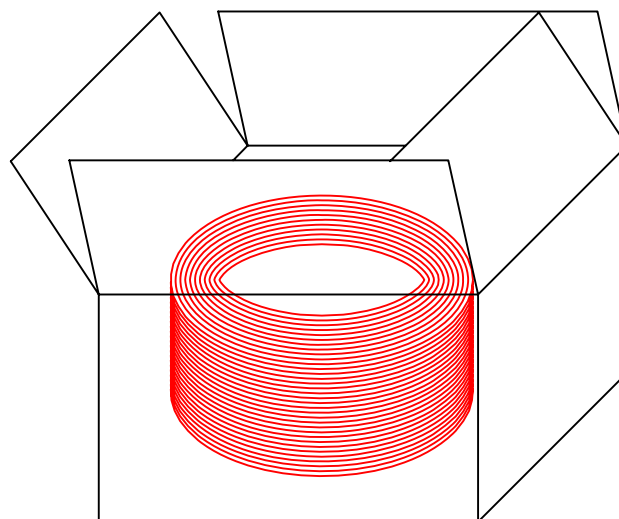

Note:
The cable should be assembled USB
AM plug with no molding, and not in
another end.

NOTE:

- 1)One reel is 300M, putting two reels in one box.
- 2)One reel is connective.
(box dimension:380*380*280MM).
- 3)The two reels are put into a big waterproof bag,
and then put them into the box(T-BLK-35-47-8C).

NET MECHANISM Corp
www.cabling-ol.net

SCALE	NONE		REV	A
UNIT	MM			
SHEET	1/1	DWG NO.		
DATE	10/15/10			
TITLE		UL 2725 CABLE		
PART NO.		BC-USB2GH-300		