

HDB15 1PORT FACE PLATE(P/N:JPFP-HD15F)

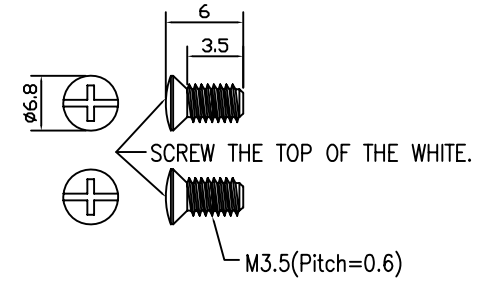
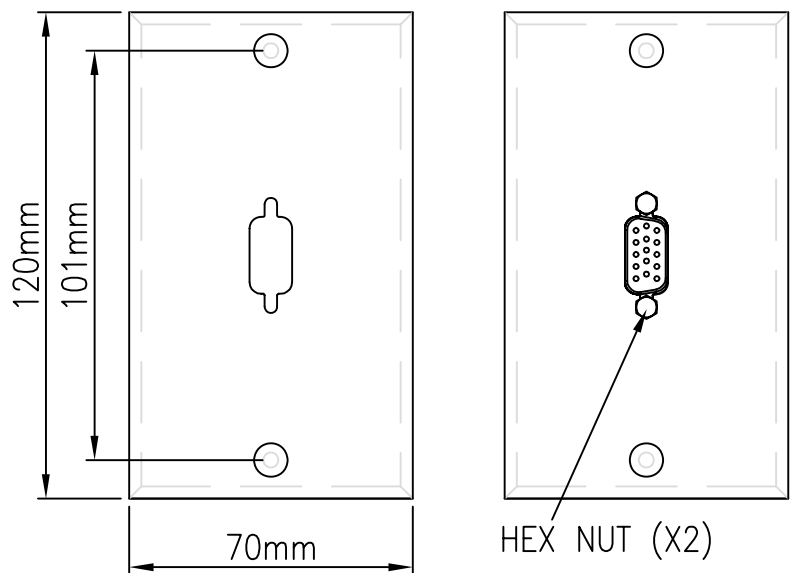

SCREW(2PCS)

NET MECHANISM Corp				
www.cabling-ol.net				
SCALE	NONE		REV	C
UNIT	MM			
SHEET	1/2	DWG NO.		
DATE	04/23/09			
TITLE				
DIN 14/M TO HD15/F+FACE PLATE				
PART NO.				
HWADC-HD15F-130				

NOTE:

1. CABLE: [(28AWG X 3COAX, EACH COAX SPIRAL SHIELDED, 75Ω, UL1354) + (24AWG X 4C) + (24AWG X 2PAIRS)], AL-FOIL AND BRAID SHIELDED WITH DRAIN WIRE, UL2919, BLACK PVC JACKET, SLOT  $\varnothing 8.5 \pm 0.15$ mm.
2. CONNECTOR:  
 P1: DIN 14P MALE, NICKEL PLATED CONTACTS AND SHELL, LOCKER TYPE.  
 P2: HIGH DENSITY D-SUB 15PIN FEMALE: SOLDER TYPE, GOLD FLASH CONTACTS, NICKEL PLATED SHELL.
3. METAL HEX NUT.
4. JAPAN METAL FACE PLATE: 1 PORT, STAINLESS STEEL, WHITE PAINTED, WITH 2PCS METAL SCREWS.
5. SHIELDED: COPPER FOIL TAPE COVER PREMOLD AND 360° SOLDER TO CONNECTOR SHELL AND CABLE BRAID.
6. MOLDED 45P BLACK PVC.
7. TESTING: 100% ELECTRICAL TEST.
8. MOLD NO.: D14M-N01, D14M-02, HD15F-110-01, HD15F-110-N01.

PIN OUT

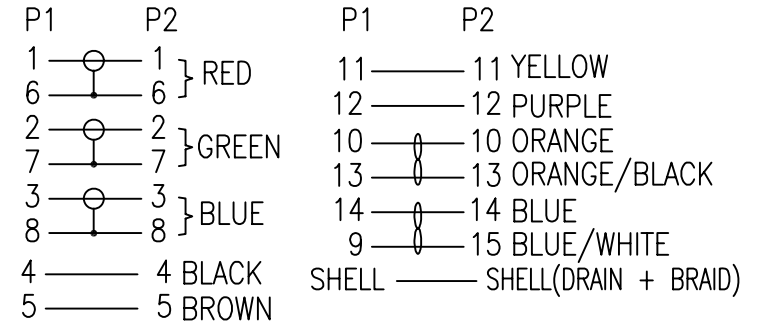

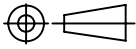
NET MECHANISM Corp <a href="http://www.cabling-ol.net">www.cabling-ol.net</a>				
SCALE	NONE		REV	C
UNIT	MM			
SHEET	2/2	DWG NO.		
DATE	04/23/09			
TITLE				
DIN 14/M TO HD15/F+FACE PLATE				
PART NO.				
HWADC-HD15F-130				