

HDB15+3.5FT FACE PLATE(P/N:JPFP-HD15F-35F)

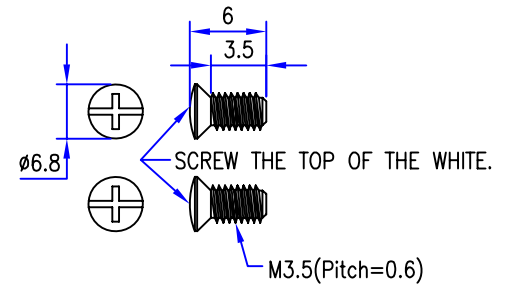
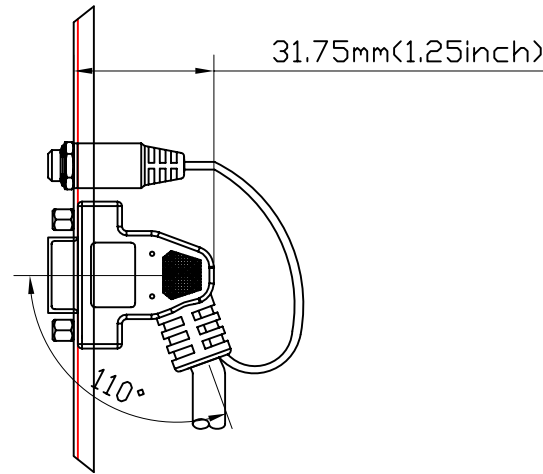
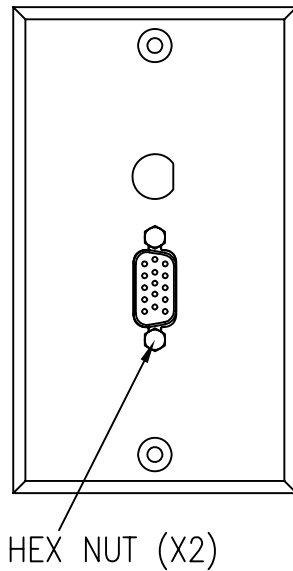
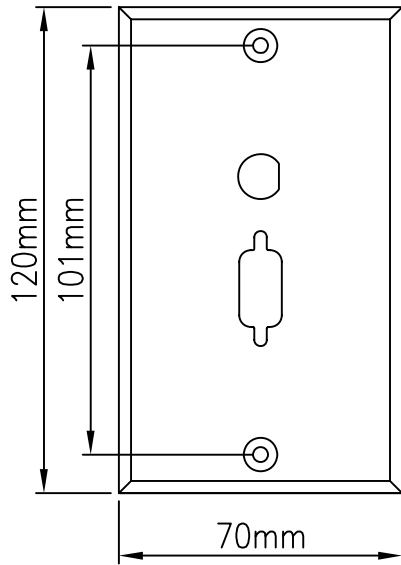
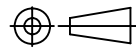

SCREW(2PCS)

NET MECHANISM Corp
www.cabling-ol.net

SCALE	NONE		REV	C
UNIT	MM			
SHEET	1/2	DWG NO.		
DATE	04/23/09			

TITLE DIN 14/M TO HD15/F+3.5ST/F

PART NO. HWADC-HD15F-35F-130

NOTE:

1. CABLE1: [(28AWG X 3COAX, EACH COAX SPIRAL SHIELDED, 75Ω , UL1354) + (24AWG X 4C) + (24AWG X 2PAIRS)], AL-FOIL AND BRAID SHIELDED WITH DRAIN WIRE, UL2919, BLACK PVC JACKET, SLOT $\phi 8.5 \pm 0.15\text{mm}$.
CABLE2: NON UL, 26AWG*2C+SPIRAL SHIELD, BLACK PVC JACK, OD $3.0 \pm 0.15\text{mm}$.
2. CONN.:
P1: DIN 14P MALE, NICKEL PLATED CONTACTS AND SHELL, LOCKER TYPE.
P2: HIGH DENSITY D-SUB 15PIN FEMALE: SOLDER TYPE, GOLD FLASH CONTACTS, NICKEL PLATED SHELL.
P3: DC3.5mm STEREO JACK, NICKEL PLATED SHELL, WITH NUT.
3. HEX NUT.
4. 1PCS JAPAN METAL PANEL: 3.5ST JACK+HD15F, STAINLESS STEEL, WHITE PAINTED, 2PCS WHITE SCREW.
5. SHIELDED: COPPER FOIL TAPE COVER PREMOLD AND 100% CONTACT TO CONNECTOR SHELL.
P1: COPPER FOIL TAPE 360° SOLDER; P2: COPPER FOIL TAPE SOLDER TO BRAID.
6. MOLDING BLACK 45 PVC.
7. TEST: 100% ELECTRICAL TEST.
8. MOLD NO.: D14M-N01, D14M-02, HD15F-110-01, HD15F-110-N01, RCA-03, RCA-N03.

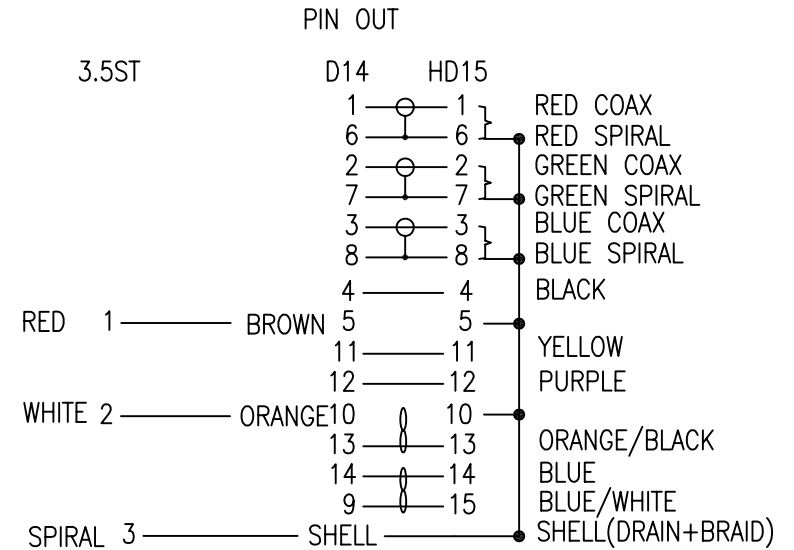

NET MECHANISM Corp
www.cabling-ol.net

SCALE	NONE		REV	C
UNIT	MM			
SHEET	1/2	DWG NO.		
DATE	04/23/09			
TITLE DIN 14/M TO HD15/F+3.5ST/F				
PART NO. HWADC-HD15F-35F-130				