

| P/N | L(M) | L(MM) | T(MM) |
|----------------|------|-------|---------|
| HWCB-24DVID-05 | 5 | 5000 | +150/-0 |
| HWCB-24DVID-07 | 7 | 7000 | +150/-0 |
| HWCB-24DVID-10 | 10 | 10000 | +150/-0 |
| HWCB-24DVID-15 | 15 | 15000 | +300/-0 |
| HWCB-24DVID-20 | 20 | 20000 | +300/-0 |
| HWCB-24DVID-30 | 30 | 30000 | +300/-0 |
| HWCB-24DVID-45 | 45 | 45000 | +300/-0 |

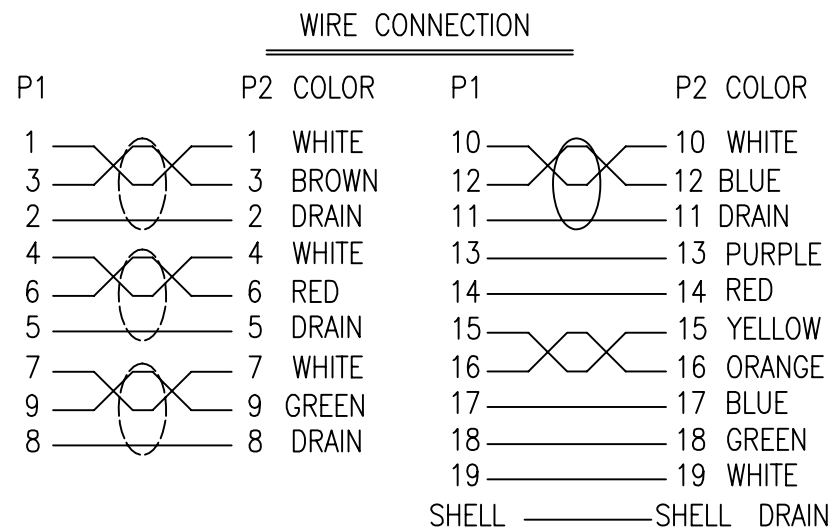
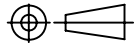

NOTE:

- CABLE: High Speed HDMI® CABLE UL20276 (24AWG*1P+AL+D+MYLAR)*4C +24AWG*1P+24AWG*5C+AL/MY+DRAIN(BARE COPPER)+BRAID(A-M ALLOY), PVC JACKET BLACK OD:9.0±0.15MM.
- CONNECTOR: P1&P2: DIN 19P FEMALE, SOLDER TYPE, TINNED PLATED CONTACTS, INSULATION: BLACK, NICKEL PLATED SHELL.
- DIN CAP:BRASS,NICKEL PLATED.
- ALL HOOD: MOLDED 45P BLACK PVC.
- SHIELDED: COPPER FOIL TAPE COVER PREMOLD AND 360° SOLDER TO CONNECTOR SHELL AND CABLE DRAIN.
- 100% OPEN AND SHORT TESTING.
- MOLD NO: D14F-N01, D14F-01.

| | | | | |
|--------------------|----------|---|-----|---|
| NET MECHANISM Corp | | | | |
| www.cabling-ol.net | | | | |
| SCALE | NONE |  | REV | E |
| UNIT | MM | | | |
| SHEET | 1/1 | DWG NO. | | |
| DATE | 12/06/10 | | | |
| TITLE | | DIN19F TO DIN19F 24AWG | | |
| PART NO. | | HWCB-24DVID-XX | | |