

1PC WALL PLATE AND 2PCS SCREW
IN A BLANK BIBBLE-BAG

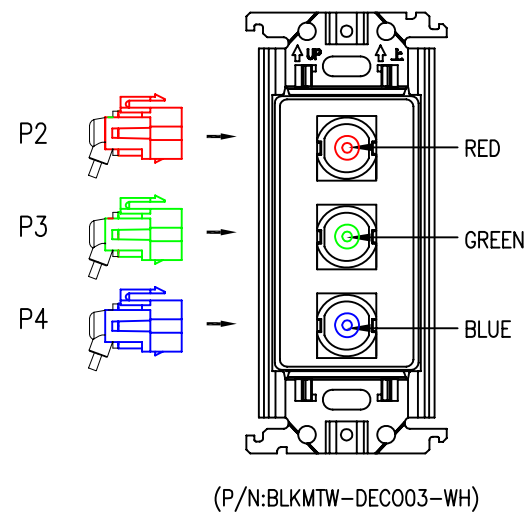

(P/N:BLKMTW-DEC003-WH)

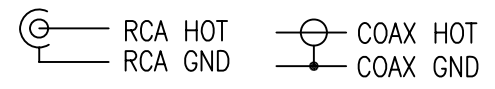
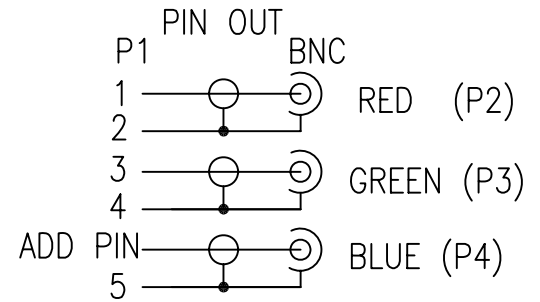

NOTE:

1. CABLE: UL20276 UL1354(30AWG+S)*5COAX(OFC)+PAPER JACKET PVC BLACK OD:7.0±0.15MM
2. CONNECTOR: P1: MINI DIN 8+1PIN FEMALE: SOLDER TYPE, GOLD FLASH CONTACTS, BLACK INSULATION, NICKEL PLATED. SHELL.
P2, P3, P4: RCA FEMALE: NICKEL PLATED CONTACTS AND SHELL, SOLDER TYPE.
3. JAPAN PLASTIC FACE PATE:3PORTS.WHITE PAINTED.
4. JAPAN 120 TYPE WALL PLATE: MATERIAL:STAINLESS STEEL, 0.6MM. COATING:WHITE.
5. SCREW:M3.5(PITCH=0.6MM),L=6MM,NICKEL PLATED, SCREW THE TOP OF THE WHITE.
6. MD8+1F MOLDED 45P BLACK PVC, RCA FEMALE MOLDED 25P WHITE(WH05) PVC,
7. TESTING: 100% ELECTRICAL TEST.
8. PACKING: EACH CABLE IN A BOX.
9. MOLD NO.: MD6F-N01, MD6F-01, RCA-N06, RCA-06.

NET MECHANISM Corp www.cabling-ol.net				
SCALE	NONE		REV	A
UNIT	MM			
SHEET	1/1	DWG NO.		
DATE	04/21/09			
TITLE MD8+1 TO 3RCA/F+FACE PLATE				
PART NO. HWFPC-RGBF-120				