

P1 MD8+1F

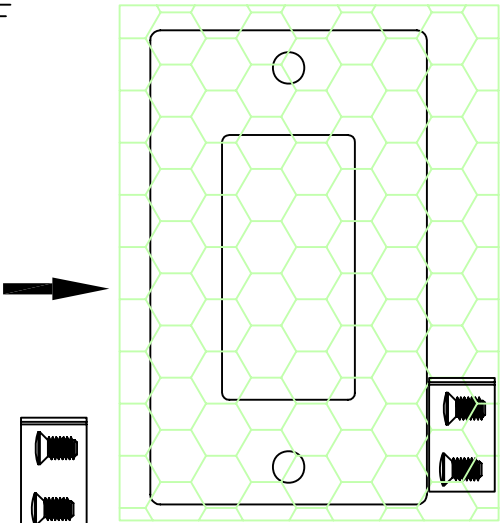

1PC WALL PLATE AND 2PCS SCREW
IN A BLANK BIBBLE-BAG

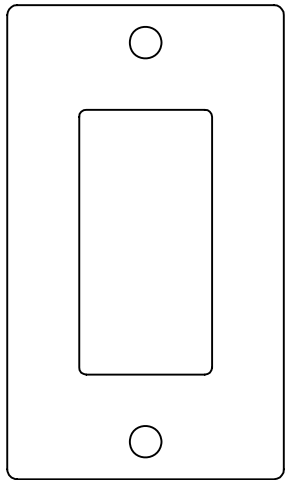
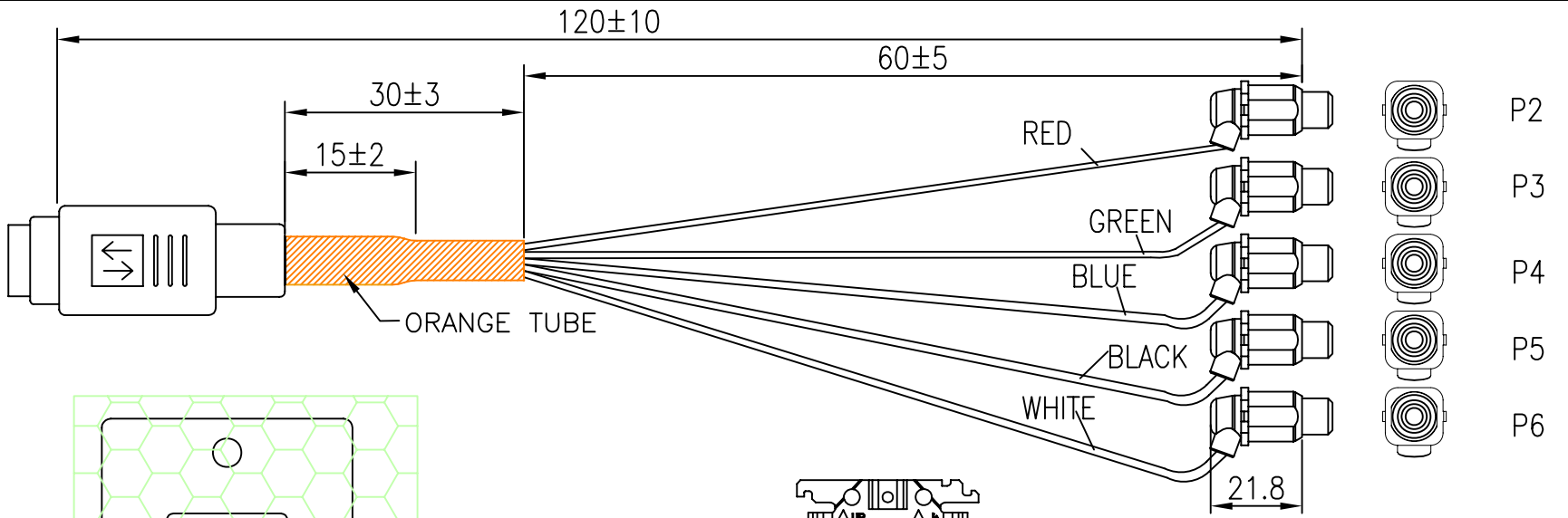
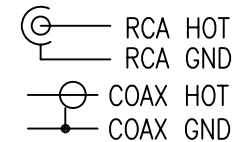
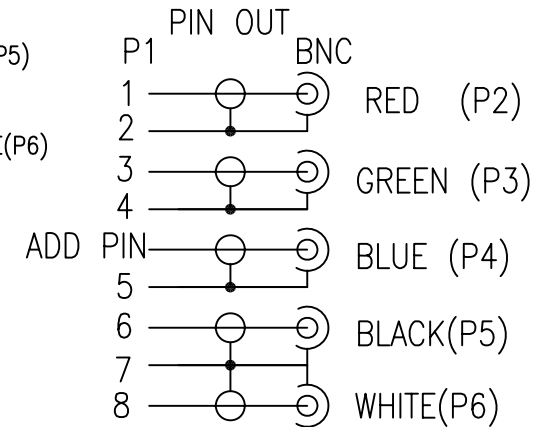
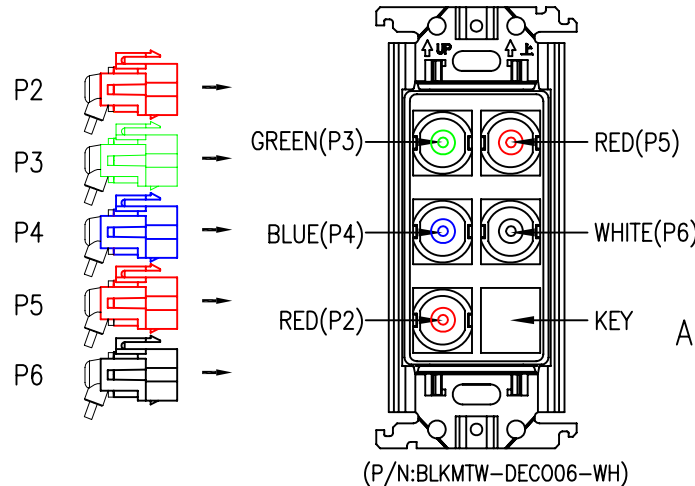

NOTE:

1. CABLE: UL20276 UL1354(30AWG+S)*5COAX(OFC)+PAPER JACKET PVC BLACK OD:7.0±0.15MM
2. CONNECTOR: P1: MINI DIN 8+1PIN FEMALE: SOLDER TYPE, GOLD FLASH CONTACTS, BLACK INSULATION, NICKEL PLATED. SHELL.
P2, P3, P4, P5, P6: RCA FEMALE: NICKEL PLATED CONTACTS AND SHELL, SOLDER TYPE.
3. JAPAN PLASTIC FACE PATE:6PORTS.WHYTE PAINTED.
4. JAPAN 120 TYPE WALL PLATE: MATERIAL:STAINLESS STEEL, 0.6MM. COATING:WHITE.
5. SCREW:M3.5(PITCH=0.6MM),L=6MM,NICKEL PLATED, SCREW THE TOP OF THE WHITE.
6. MD8+1F MOLDED 45P BLACK PVC,RCA FEMALE MOLDED 25P WHITE(WH05) PVC.
7. TESTING: 100% ELECTRICAL TEST.
8. PACKING: EACH CABLE IN A BOX.
9. MOLD NO.: MD6F-N01, MD6F-01, RCA-N06,RCA-06.

NET MECHANISM Corp
www.cabling-ol.net

SCALE	NONE		REV	A
UNIT	MM			
SHEET	1/1	DWG NO.		
DATE	04/21/09	TITLE		
		MD8+1F TO 5RCA/F+FACE PLATE		
PART NO.		HWFPC-RGBRWF-120		