

DECORA 4 PORT(07X-I04-WH-J)

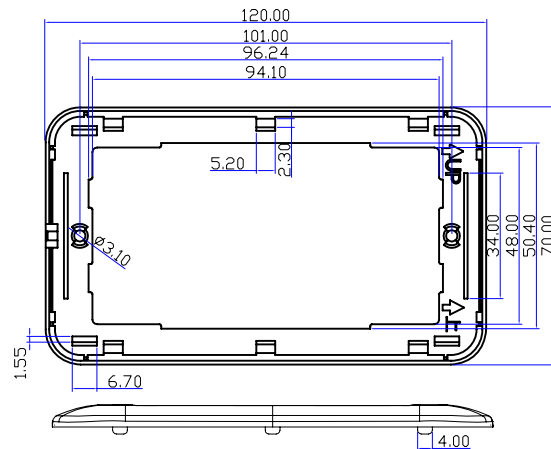

JAPANESE FACE PLATE(BACK HOOD)

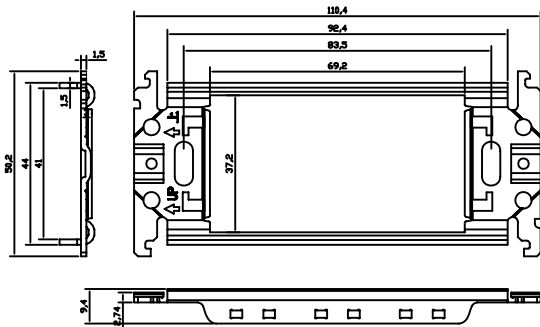
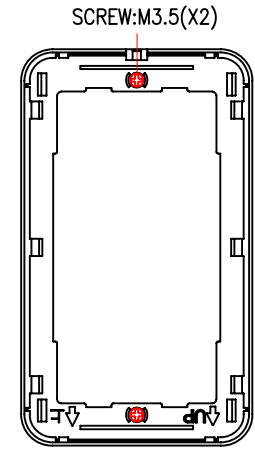

METAL FRAME

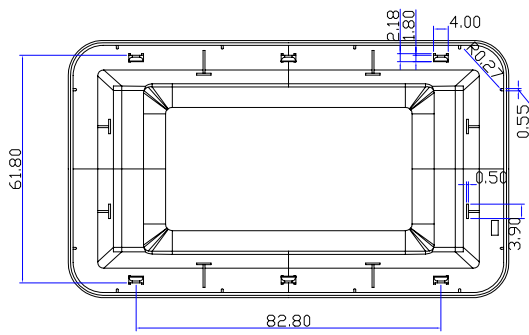

JAPANESE FACE PLATE(FRONT HOOD)

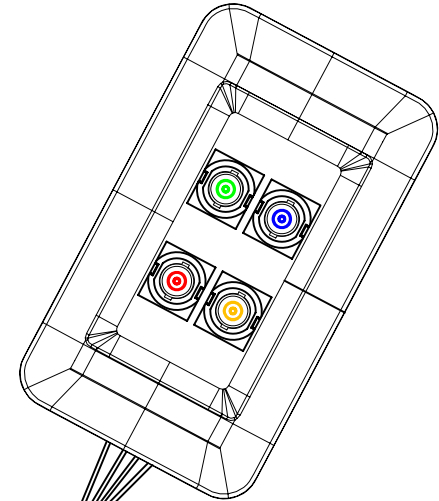

ASSEMBLY DRAWING

- NOTE:
- 1.DECORA:4 PORT,MATERIAL:PC,COLOR:WHITE.
 - 2.METAL FRAME(PART NO.:PANASONIC WT3700020).
 - 3.JAPANESE FACE PLATE(BACK HOOD)
 - 4.JAPANESE FACE PLATE(FRONT HOOD)
 - 5.SCREW:M3.5, ϕ 5.0*5.3MM,NICKEL PLATED

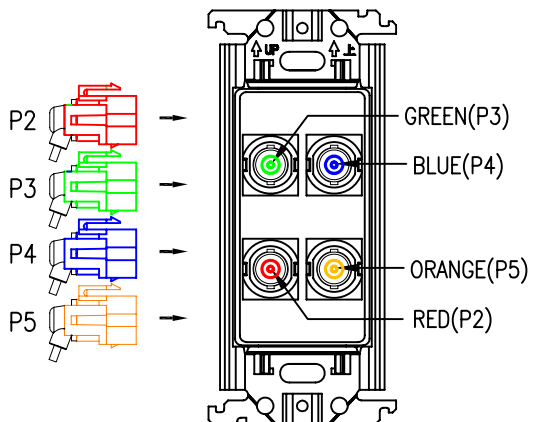

NET MECHANISM Corp					
www.cabling-ol.net					
SCALE	NONE		REV	B	
UNIT	MM				
SHEET	1/2	DWG NO.			
DATE	10/25/10				
TITLE					
MD8+1F TO 4BNC+FACE PLATE					
PART NO.					
PFPC-4BNCF-120					

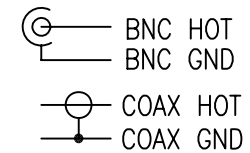
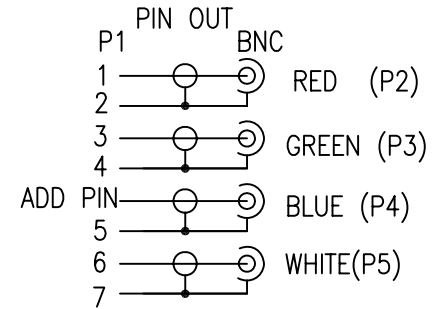
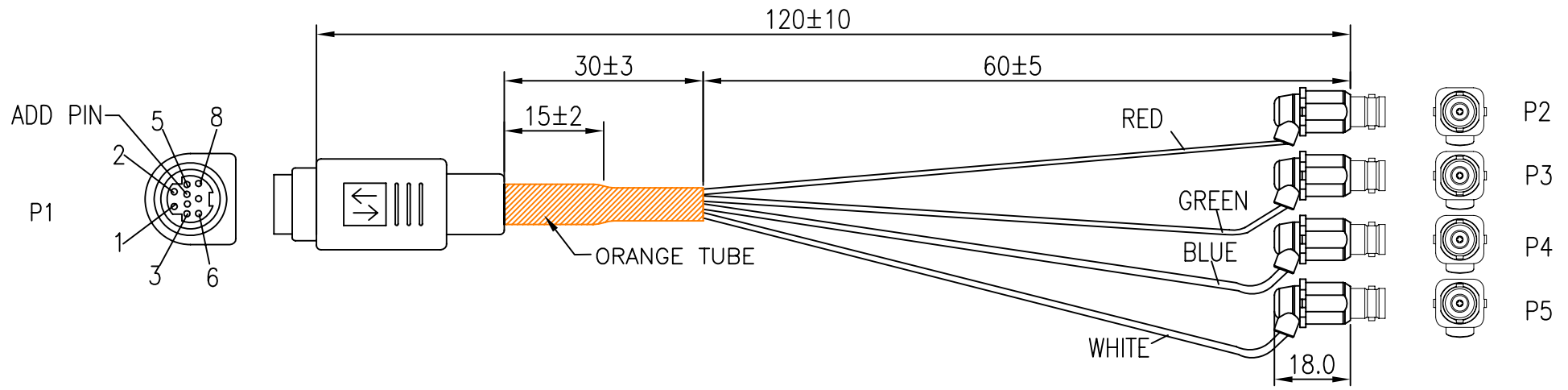

NOTE:

- CABLE:UL20276 UL1354(30AWG+S)*5COAX(OFC)+PAPER JACKET PVC BLACK OD:7.0±0.15MM
- CONN: P1: MINI DIN 8+1PIN FEMALE: SOLDER TYPE, GOLD FLASH CONTACTS, BLACK INSULATION, NICKEL PLATED. SHELL.
P2, P3, P4,P5: BNC FEMALE WHITE INSULATION,COPPER COVER, 75 ohm.
- HOOD: MD8+1F MOLDED 45P BLACK PVC,BNC FEMALE MOLDED 25P WHITE(WH05) PVC.
- TESTING: 100% ELECTRICAL TEST.
- MOLD NO: MD6F-N01, MD6F-01, BNC-N05,BNC-05.

NET MECHANISM Corp www.cabling-ol.net				
SCALE	NONE		REV	B
UNIT	MM			
SHEET	2/2	DWG NO.		
DATE	10/25/10			
TITLE MD8+1F TO 4BNC+FACE PLATE				
PART NO. PFPC-4BNCF-120				