

DECORA 4 PORT(07X-I04-WH-J)

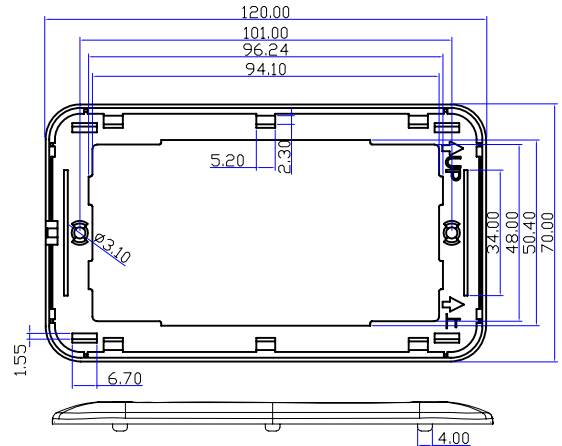

JAPANESE FACE PLATE(BACK HOOD)

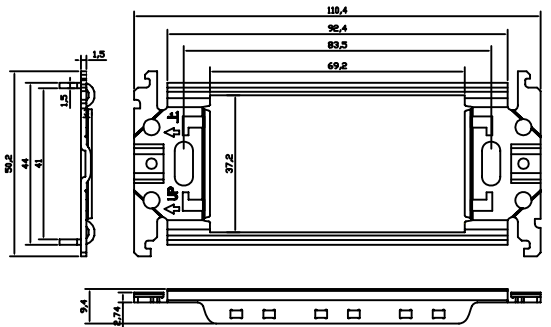
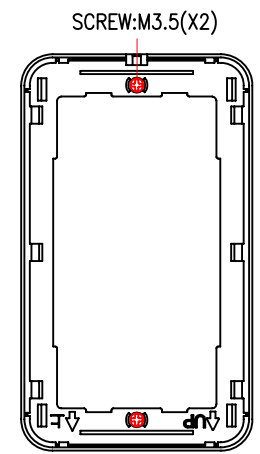

METAL FRAME

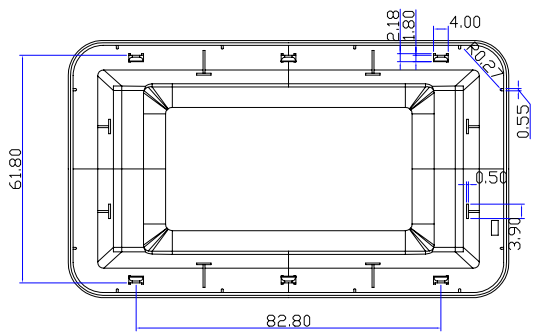

JAPANESE FACE PLATE(FRONT HOOD)

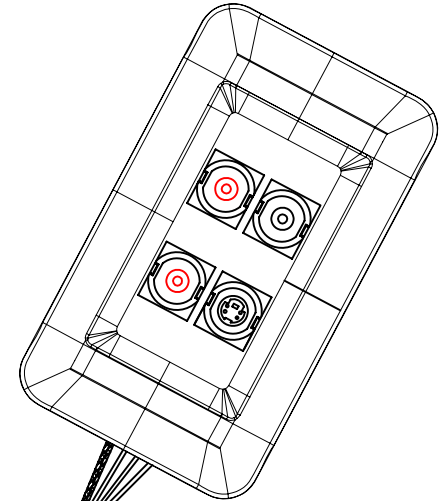

ASSEMBLY DRAWING

NOTE:  
 1.DECORA:4 PORT,MATERIAL:PC,COLOR:WHITE.  
 2.METAL FRAME(PART NO.:PANASONIC WT3700020).  
 3.JAPANESE FACE PLATE(BACK HOOD)  
 4.JAPANESE FACE PLATE(FRONT HOOD)  
 5.SCREW:M3.5,φ5.0\*5.3MM,NICKEL PLATED

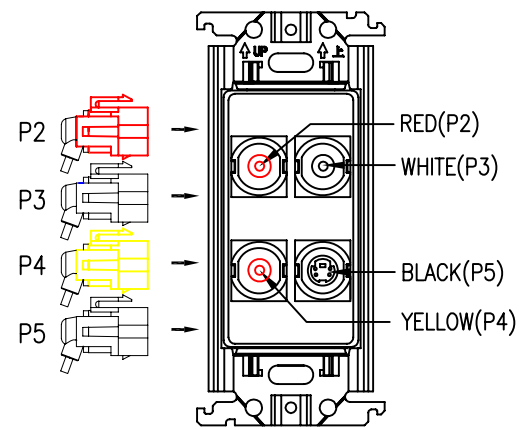

|                                  |          |         |     |   |
|----------------------------------|----------|---------|-----|---|
| NET MECHANISM Corp               |          |         |     |   |
| www.cabling-ol.net               |          |         |     |   |
| SCALE                            | NONE     |         | REV | A |
| UNIT                             | MM       |         |     |   |
| SHEET                            | 1/2      | DWG NO. |     |   |
| DATE                             | 03/01/10 |         |     |   |
| TITLE                            |          |         |     |   |
| MD8+1F TO 3RCA/F+MD4F+FACE PLATE |          |         |     |   |
| PART NO.                         |          |         |     |   |
| PFPC-MD4F-3RCAF-120              |          |         |     |   |

