

- NOTE:
- 1.DECORA:3 PORT,MATERIAL:PC,COLOR:WHITE.
  - 2.METAL FRAME(PART NO.:PANASONIC WT3700020).
  - 3.JAPANESE FACE PLATE(BACK HOOD)
  - 4.JAPANESE FACE PLATE(FRONT HOOD)
  - 5.SCREW:M3.5,φ5.0\*5.3MM,NICKEL PLATED

NET MECHANISM Corp				
www.cabling-ol.net				
SCALE	NONE		REV	A
UNIT	MM			
SHEET	1/2	DWG NO.		
DATE	03/01/10			
TITLE				
MD8+1F TO 3RCA/F-FACE				
PART NO.				
PFPC-RGBF-120				

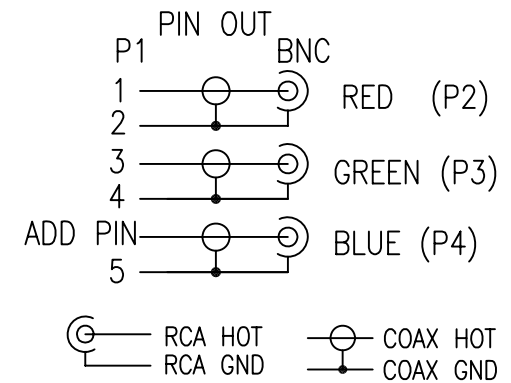
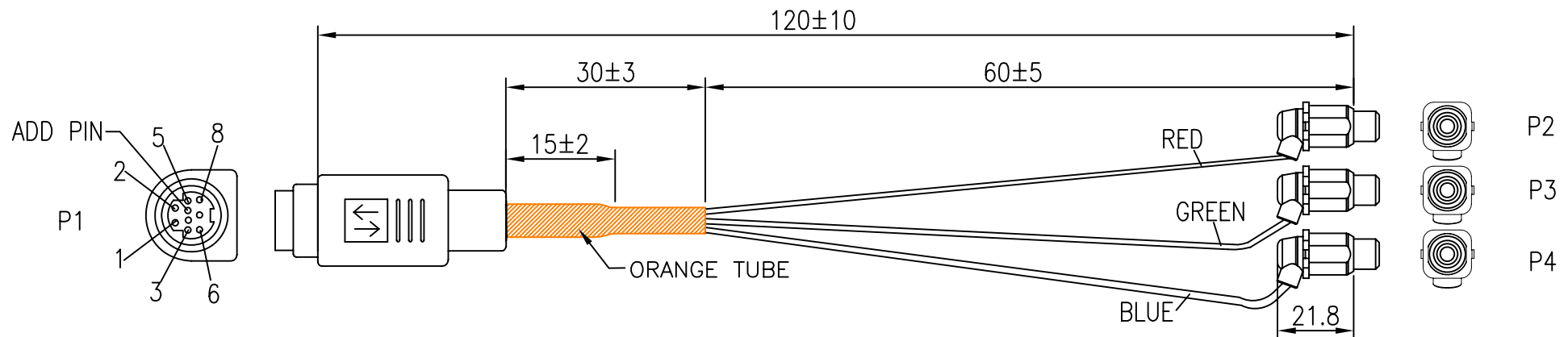

NOTE:

1. CABLE UL20276 UL1354(30AWG+S)\*5COAX(OFC)+PAPER JACKET PVC BLACK OD:7.0±0.15MM
2. CONNECTOR: P1: MINI DIN 8+1PIN FEMALE: SOLDER TYPE, GOLD FLASH CONTACTS, BLACK INSULATION, NICKEL PLATED. SHELL.  
P2, P3, P4: RCA FEMALE: NICKEL PLATED CONTACTS AND SHELL, SOLDER TYPE.
3. MD8+1F MOLDED 45P BLACK PVC,RCA FEMALE MOLDED 25P WHITE(WH05) PVC.
4. TESTING:100% ELECTRICAL TEST.
5. MOLD NO: MD6F-N01, MD6F-01, RCA-N06,RCA-06.

NET MECHANISM Corp			
www.cabling-ol.net			
SCALE	NONE		REV A
UNIT	MM		
SHEET	2/2	DWG NO.	
DATE	03/01/10		
TITLE MD8+1F TO 3RCA/F-FACE			
PART NO. PFPC-RGBF-120			