

NOTE:
 1.DECORA:4 PORT,MATERIAL:PC,COLOR:WHITE.
 2.METAL FRAME(PART NO.:PANASONIC WT3700020).
 3.JAPANESE FACE PLATE(BACK HOOD)
 4.JAPANESE FACE PLATE(FRONT HOOD)
 5.SCREW:M3.5,φ5.0*5.3MM,NICKEL PLATED

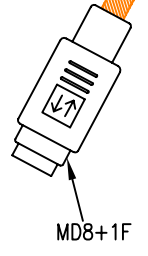

NET MECHANISM Corp				
www.cabling-ol.net				
SCALE	NONE	⊕	REV	A
UNIT	MM			
SHEET	1/2	DWG NO.		
DATE	03/01/10			
TITLE				
MD8+1F TO 4RCA/F+FACE PLATE				
PART NO.				
PFPC-RGBOF-120				

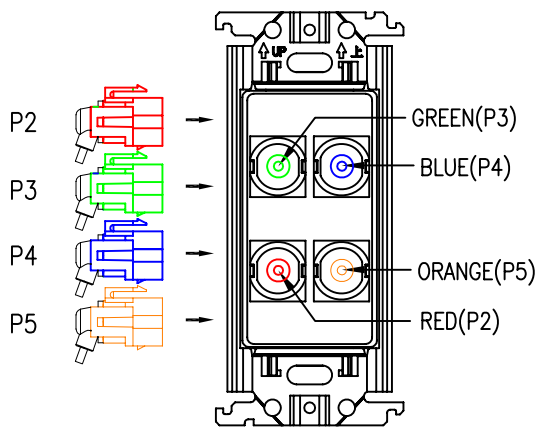
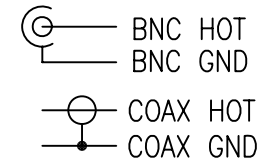
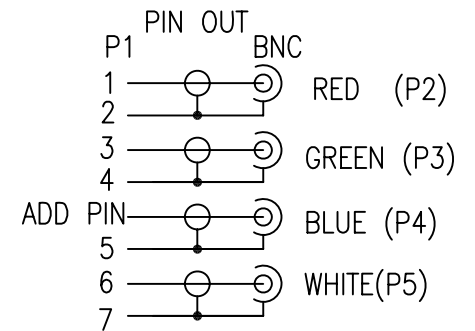
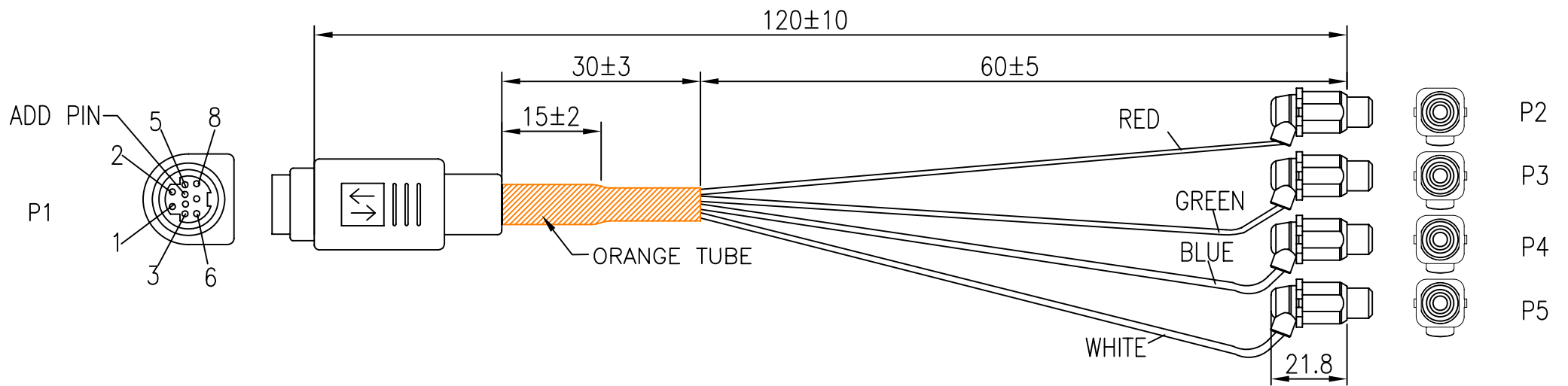

NOTE:

1. CABLE:UL20276 UL1354(30AWG+S)*5COAX(OFC)+PAPER JACKET PVC BLACK OD:7.0±0.15MM
2. CONNECTOR: P1: MINI DIN 8+1PIN FEMALE: SOLDER TYPE, GOLD FLASH CONTACTS, BLACK INSULATION, NICKEL PLATED. SHELL.
P2, P3, P4,P5: RCA FEMALE: NICKEL PLATED CONTACTS AND SHELL, SOLDER TYPE.
3. MD8+1F MOLDED 45P BLACK PVC,RCA FEMALE MOLDED 25P WHITE(WH05) PVC.
4. TESTING: 100% ELECTRICAL TEST.
5. PACKING: EACH CABLE IN A BOX.
6. MOLD NO.: MD6F-N01, MD6F-01, RCA-N06,RCA-06.

NET MECHANISM Corp
www.cabling-ol.net

SCALE	NONE		REV	A
UNIT	MM			
SHEET	2/2	DWG NO.		
DATE	03/01/10			
TITLE	MD8+1F TO 4RCA/F+FACE PLATE			
PART NO.	PFPC-RGBOF-120			