

DECORA 3 PORT(07X-I03-WH-J)

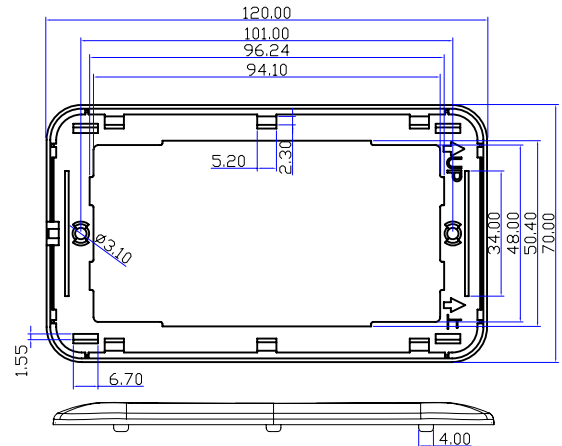

JAPANESE FACE PLATE(BACK HOOD)

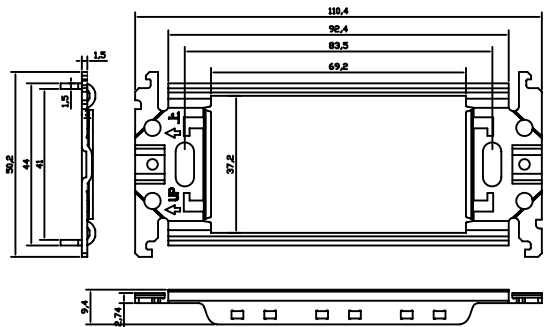
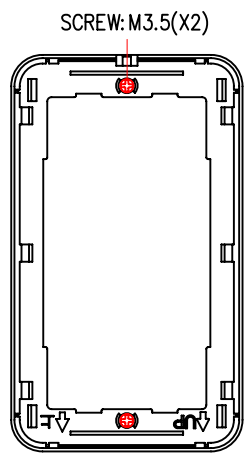

METAL FRAME

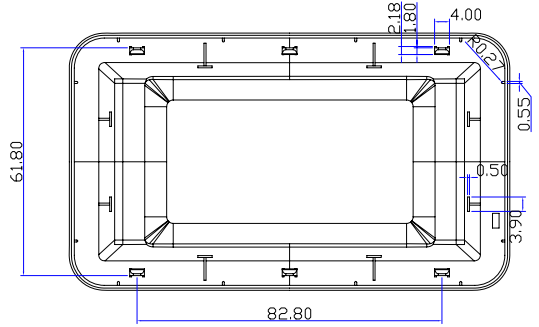

JAPANESE FACE PLATE(FRONT HOOD)

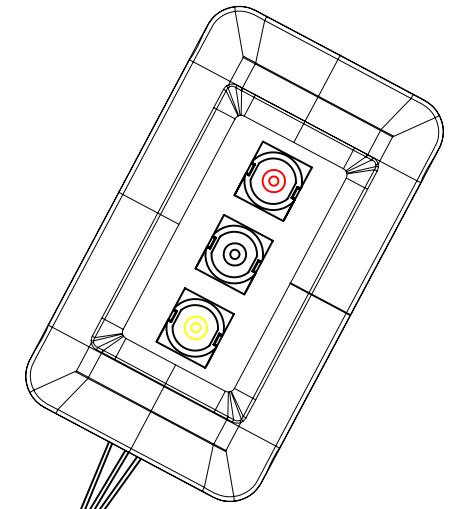

ASSEMBLY DRAWING

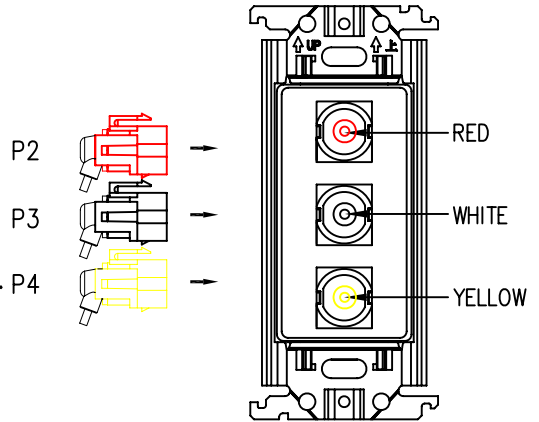

- NOTE:  
 1.DECORA: 3 PORT,MATERIAL:PC,COLOR: WHITE.  
 2.METAL FRAME(PART NO.:PANASONIC WT3700020).P4  
 3.JAPANESE FACE PLATE(BACK HOOD)  
 4.JAPANESE FACE PLATE(FRONT HOOD)  
 5.SCREW: M3.5,φ5.0\*5.3MM,NICKEL PLATED

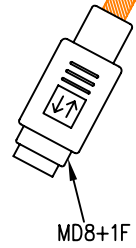

MD8+1F

NET MECHANISM Corp www.cabling-ol.net				
SCALE	NONE		REV	B
UNIT	MM		DWG NO.	
SHEET	1/2	DATE 09/23/10		
TITLE MD8+1F TO 3RCA/F-FACE				
PART NO. PFPC-YRWF-120				

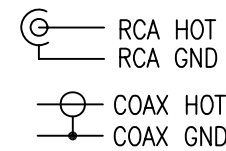
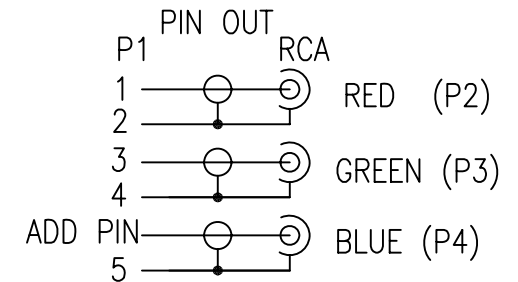
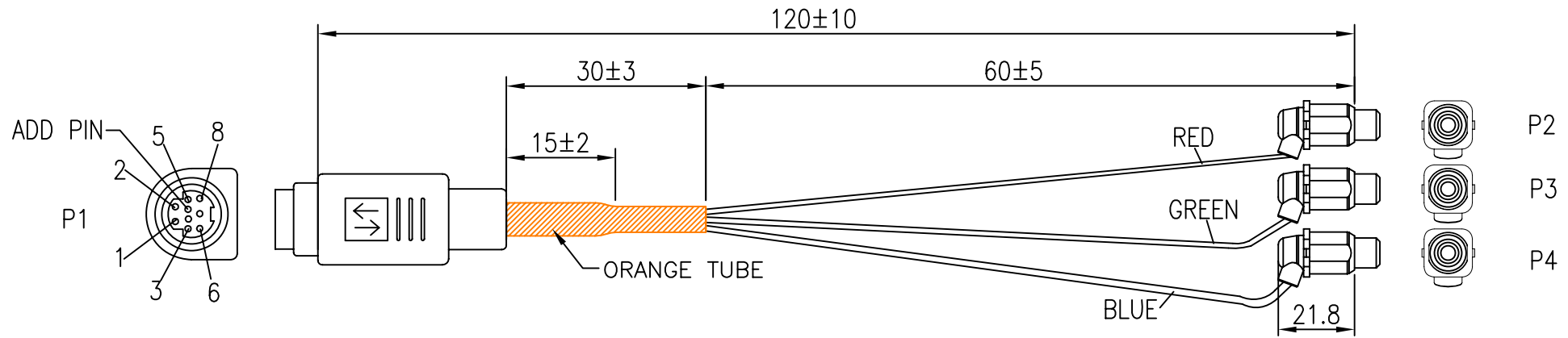

- NOTE:
1. CABLE UL20276 UL1354(30AWG+S)\*5COAX(OFC)+PAPER JACKET PVC BLACK OD:7.0±0.15MM
  2. CONNECTOR: P1: MINI DIN 8+1PIN FEMALE: SOLDER TYPE, GOLD FLASH CONTACTS, BLACK INSULATION, NICKEL PLATED. SHELL.  
P2, P3, P4: RCA FEMALE: NICKEL PLATED CONTACTS AND SHELL, SOLDER TYPE.
  3. MD8+1F MOLDED 45P BLACK PVC,RCA FEMALE MOLDED 25P WHITE(WH05) PVC.
  4. TESTING:100% ELECTRICAL TEST.
  5. MOLD NO: MD6F-N01, MD6F-01, RCA-N06,RCA-06.

NET MECHANISM Corp www.cabling-ol.net				
SCALE	NONE		REV	A
UNIT	MM			
SHEET	2/2	DWG NO.		
DATE	02/27/10			
TITLE	MD8+1F TO 3RCA/F-FACE			
PART NO.	PFPC-YRWF-120			