

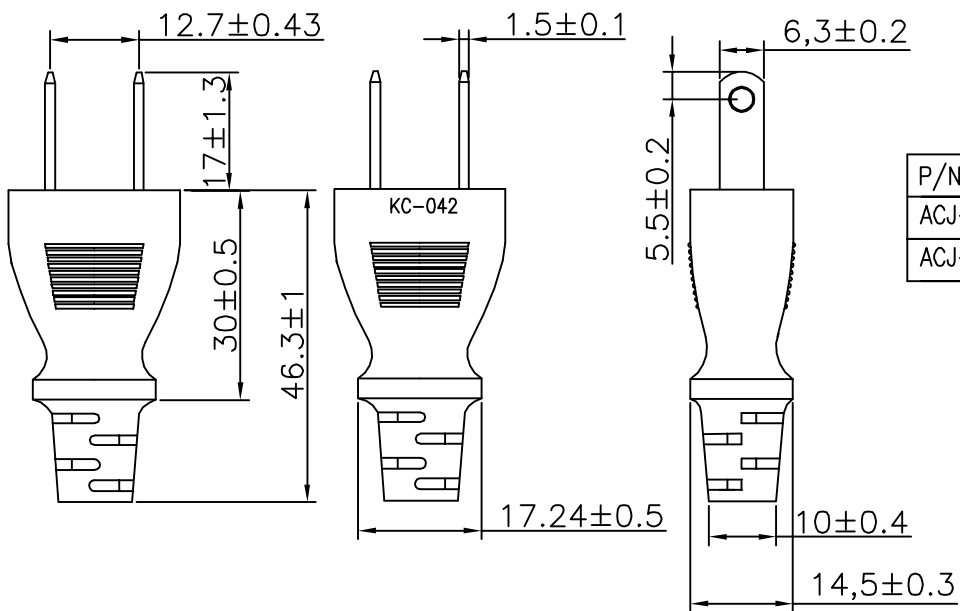

Point marking

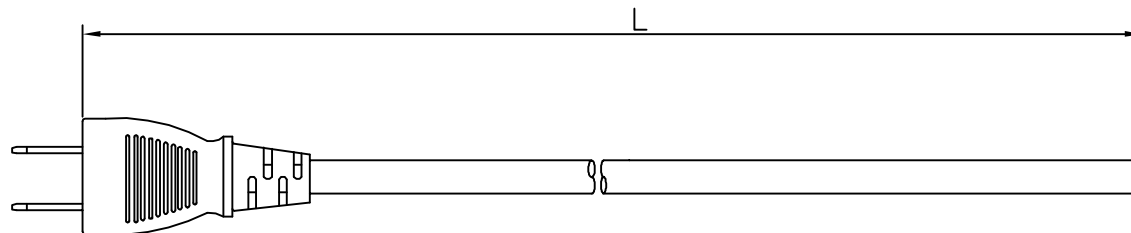

P/N	L(MM)	TOLERANCE(MM)
ACJ-2P-WOG-02	2000	±50
ACJ-2P-WOG-03	3000	±50

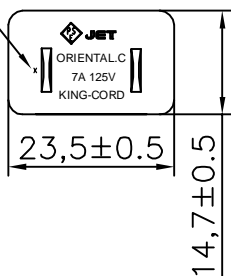
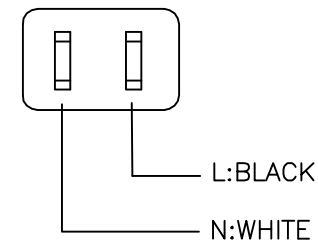

KC-042: 

- 1.CABLE:VCTFK 2\*0.75mm<sup>2</sup> JACKET BLACK OD=ø4.3\*6.6±0.1mm
- 2.PVC:88 A PVC BLACK
- 3.COLOR:BLACK
- 4.Tie:BLACK

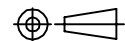
NET MECHANISM Corp www.cabling-ol.net				
SCALE	NONE		REV	B
UNIT	MM			
SHEET	1/1	DWG NO.K42001Q8XXXBR		
DATE	17/07/31			
TITLE				
PART NO.				