

RevNo	Revision note	Rev-By	RevDate	Signature	Checked



MINI BLOCK - WALL MOUNT TYPE

ITEM NO: FA-2300-FH-4P



FEATURES:

- Mini Block FA-2300FH Series for Wall-Mount Type
- For 4pcs of F45 system (45x45mm) Modules
(or)
For 8of F45 system (22.5x45mm) Half Modules
- Included 3 pcs Cover Plate
- Included 1 pc insert (for Cable Output)

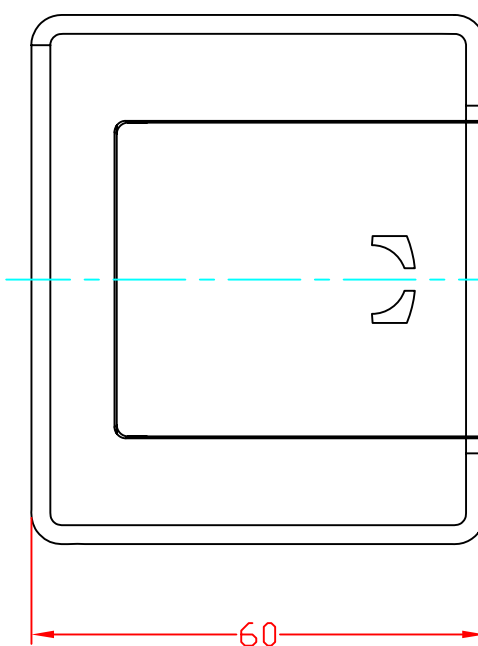
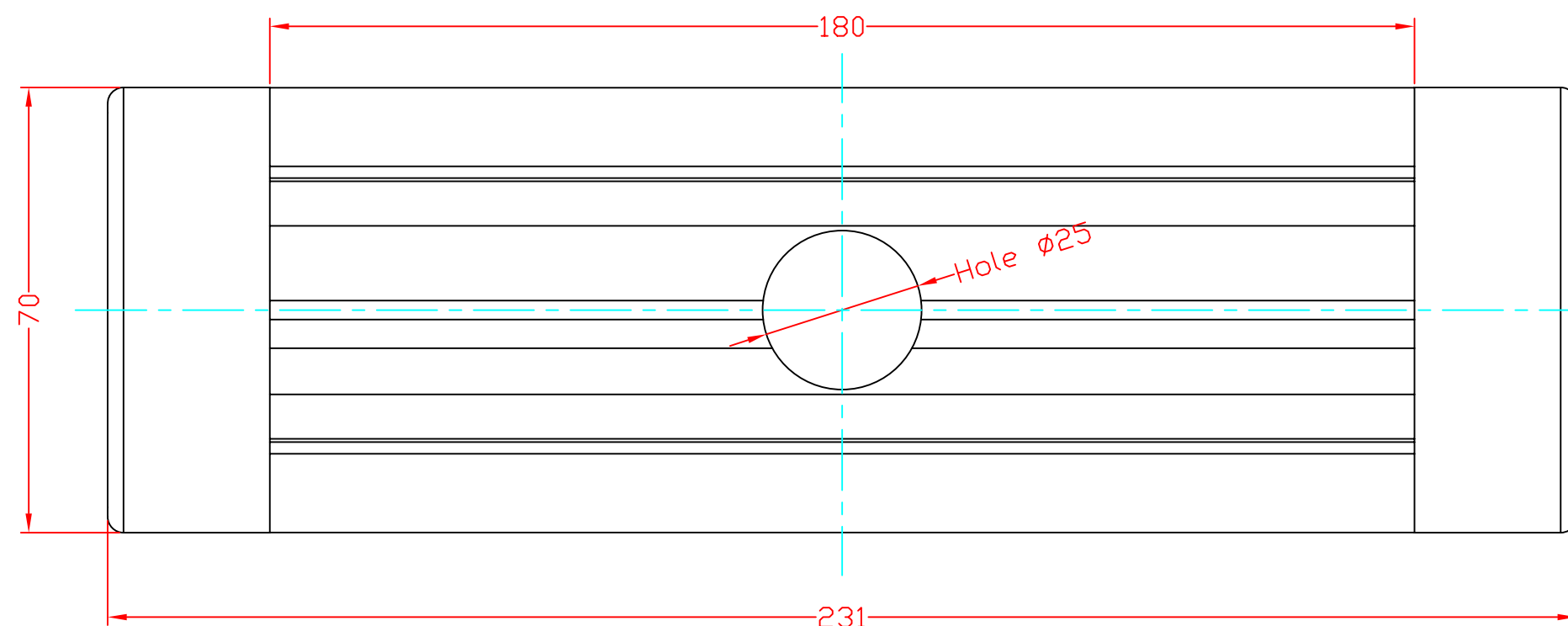
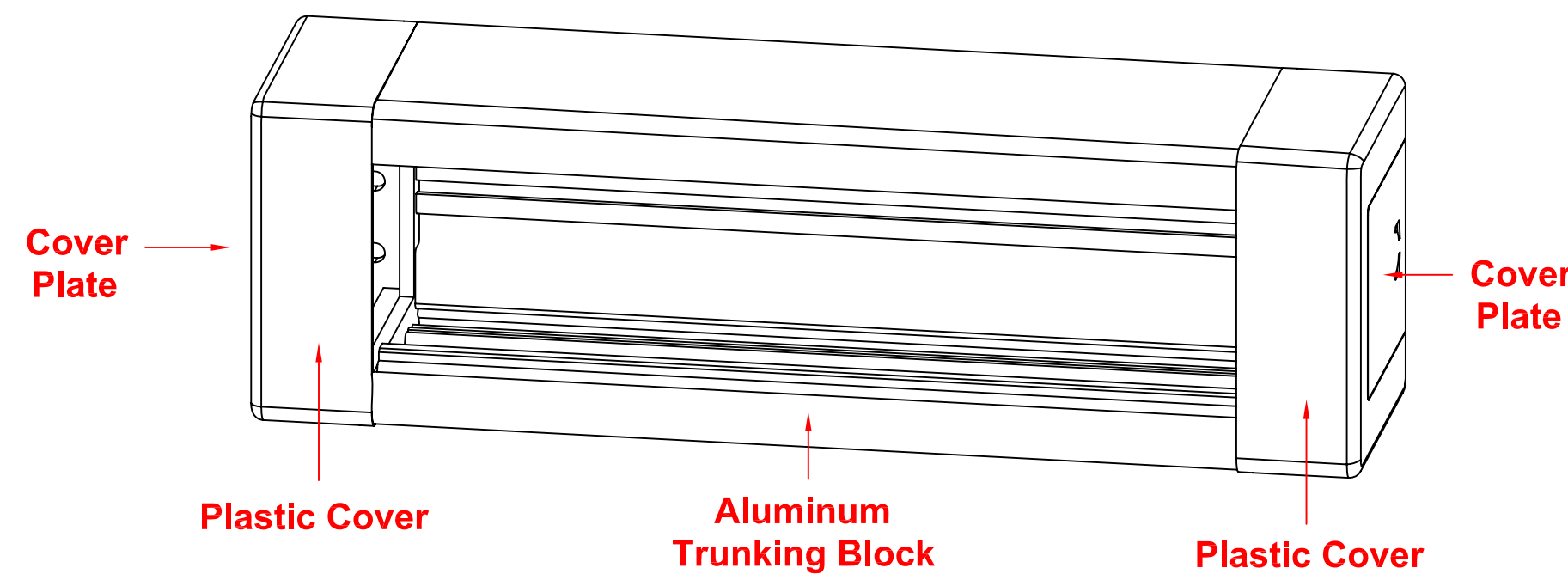
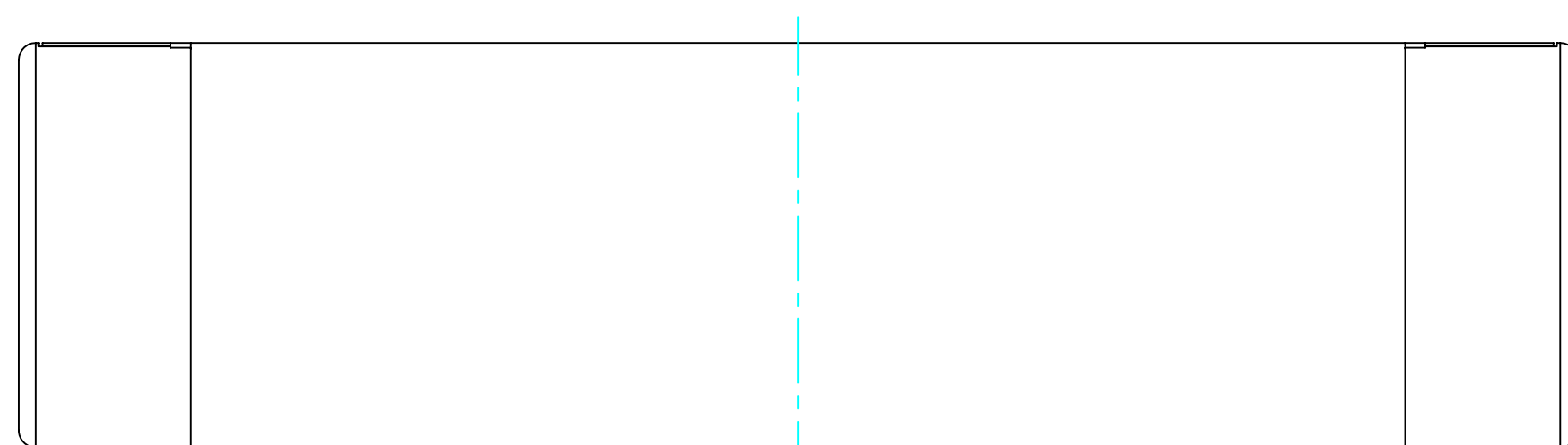

ITEM NO.	FA-2300-FH-4P				
CUSTOMER NO.					
DESIGNED BY	DATE	14/12/16	UNIT	MM	
ALEX	SCALE	1:1	VER.	1	
NO.	Checked by				
APPR:	Approved by -date				