

RevNo	Revision note	Rev-By	RevDate	Signature	Checked

DESK-TOP - PLASTIC FOOT STAND

ITEM NO: FA-2300-OP-PS

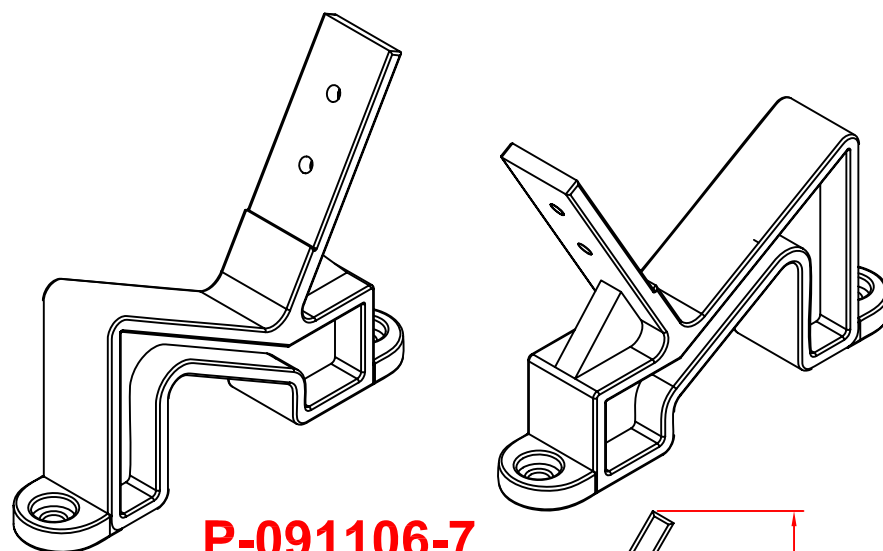
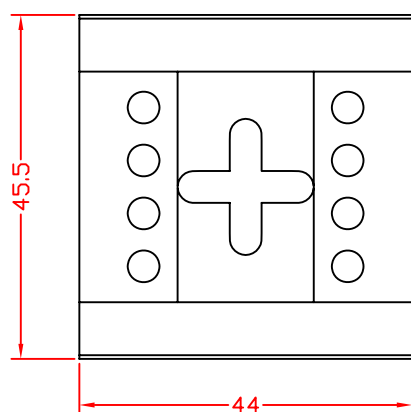
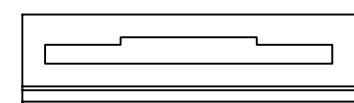
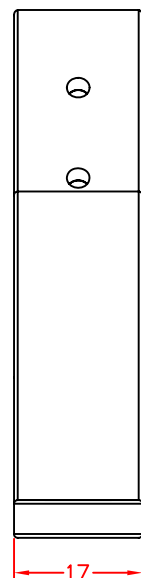
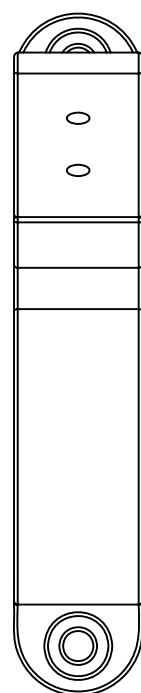

P-091106-7

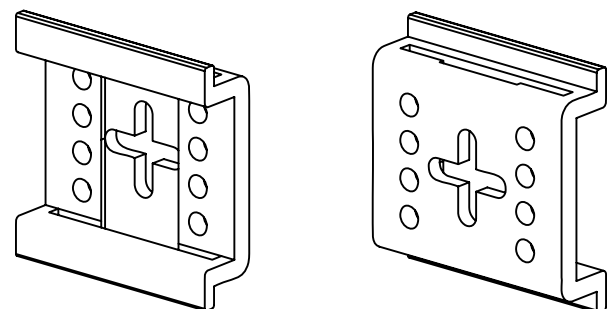
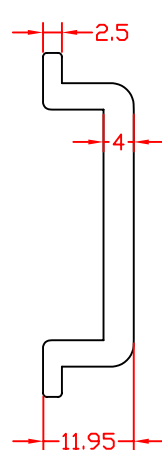
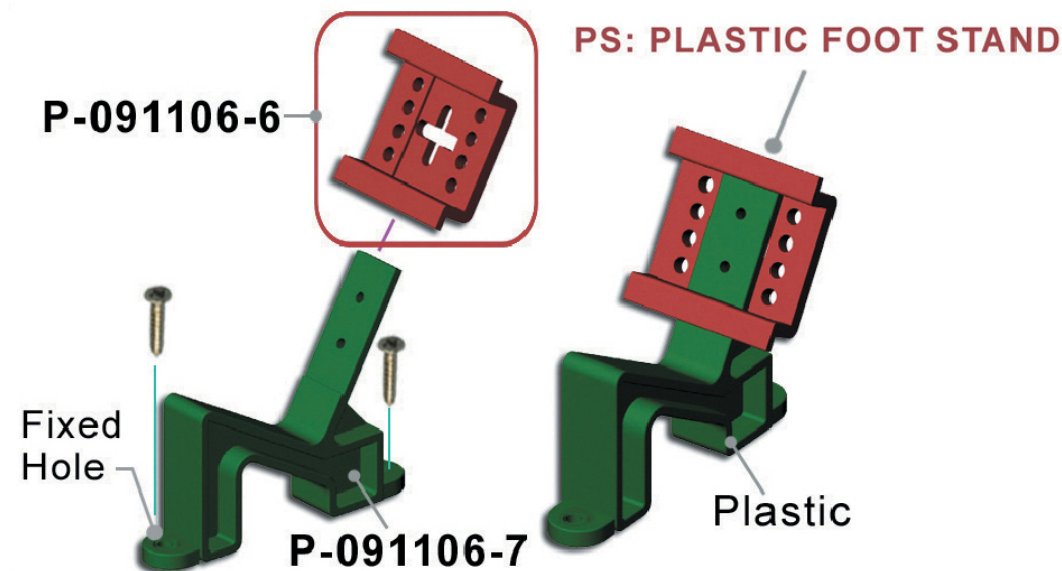
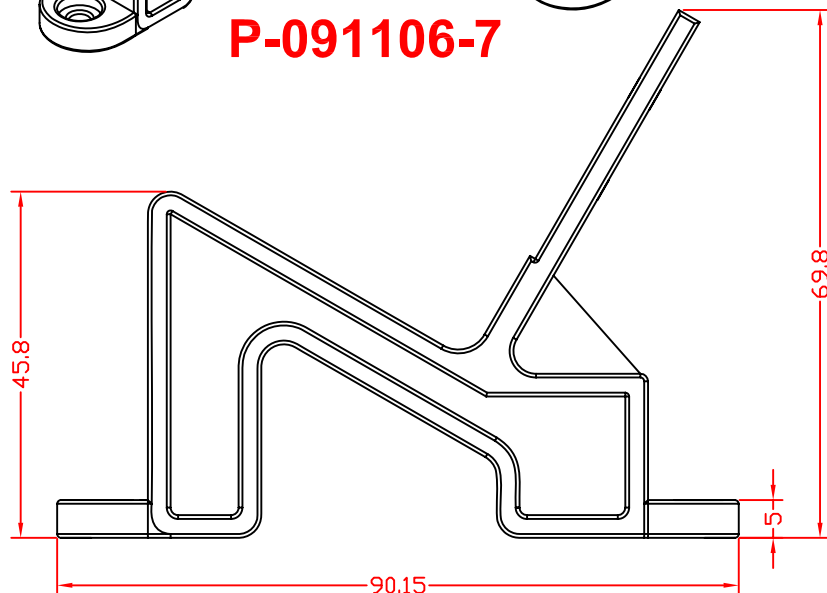

P-091106-6

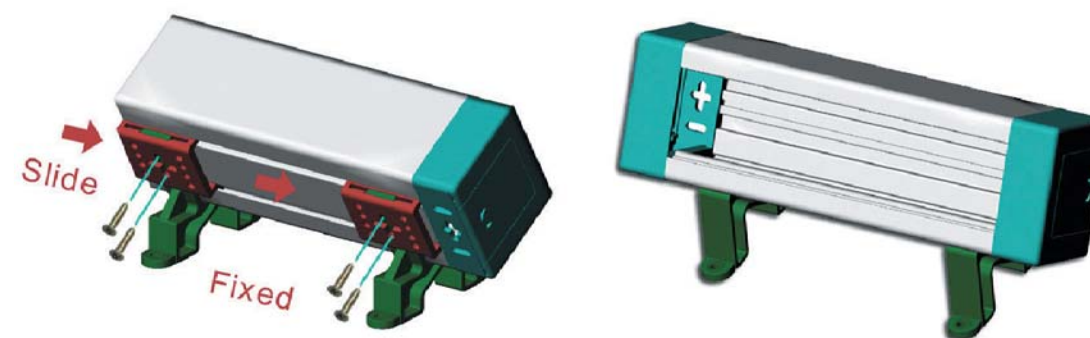

ITEM NO.	FA-2300-OP-PS				
CUSTOMER NO.	XXXX				
DESIGNED BY	DATE	04XXXX	UNIT	MM	
	ALEX	SCALE	xx	VER.	1
NO.	Checked by				
APPR:	Approved by	-date			